

Marine microbial response to heavy metals: Mechanism, Implications and Future prospect

Abhay B. Fulke^{1#}, Atul Kotian¹ and Manisha D. Giripunje²

¹Microbiology Division, CSIR-National Institute of Oceanography (CSIR-NIO), Regional Centre, Lokhandwala Road, Four Bungalows, Andheri (West), Mumbai-400053, Maharashtra, India.

²Sevadal MahilaMahavidyalaya, Nagpur 440009, India

#Corresponding Author Email: afulke@nio.org; abhay_fulke@yahoo.co.in

Phone: +91-022 26359605, Extn No 1414

Abstract

Growing levels of pollution in marine environment has been a matter of serious concern in recent years. Increased levels of heavy metals due to improper waste disposal has led to serious repercussions. This has increased occurrences of heavy metals in marine fauna. Marine microbes are large influencers of nutrient cycling and productivity in oceans. Marine bacteria show altered metabolism as a strategy against metal induced stress. Understanding these strategies used to avoid toxic effects of heavy metals can help in devising novel biotechnological applications for ocean clean-up. Using biological tools for remediation has advantages as it does not involve harmful chemicals and it shows greater flexibility to environmental fluctuations. This review provides a comprehensive insight on marine microbial response to heavy metals and sheds light on existing knowledge about and paves for new avenues in research for bioremediation strategies.

Keywords: Heavy metals, Marine microbes, Bioremediation, Ocean clean-up

1. Introduction:

Heavy metals are a class of metals defined by characteristically having density above 5 g/cm^3 and are known to be common pollutants in both terrestrial and aquatic environments (Hawkes 1997, Mohseniet *al.* 2018). Heavy metals in marine sediments have both natural and anthropogenic origin; their distribution and accumulation are largely influenced by sediment texture, mineralogical composition, reduction/oxidation state, adsorption and desorption processes and physical transport (Buccolieriet *al.* 2006). These metals tend to be environmentally persistent and pose a severe threat to the biota exposed to them (Rousk and Rousk 2018). Heavy metals ions also compete with essential metal ions for binding with biomolecules (Wang *et al.* 1997) which explains their disruptive physiological effects.

Biological systems, through evolution have acquired ability to utilise some metals for essential biological functions like oxygen transportation, photosynthesis and transmitting nerve impulses (Altenburger 2011). Among these metals Na^+ , K^+ , Ca^{2+} , Mg^{2+} are termed group I, as they are considered to be essential for stabilizing organic structures. There are additional metals such as Vanadium (V), Chromium (Cr), Manganese (Mn), Iron (Fe), Cobalt (Co), Nickel (Ni), Copper(Cu), Zinc(Zn), Molybdenum (Mo), Boron(B), Silicon(Si), Selenium (Se), Fluorine(F), Iodine(I), Arsenic (As), Boron(Br) and Tin(Sn), termed group II, which are found in some living organisms, but not in all. Most of these are required as enzyme cofactors, for structural integrity, or to provide screening of the electrostatic interactions in the water phase (Petukh and Alexov 2014; Jaishankaret *al.* 2014). Moreover, they are required in trace quantities and when they cross their threshold values, they become toxic (Rainbow and Furness 1990, Zwolak 2015). Speciation in metals can also reduce or enhance toxicity. Cr(III) (trivalent Chromium) is known to be essential trace element for some bacteria, whereas Cr(VI)(hexavalent Chromium) is highly toxic, similarly organic forms of Mercury are more toxic than inorganic and elemental Mercury (Keil 2011, Park and Zheng 2012). Metal-protein complexes of metals like Hg are inherently toxic and trace elements like Zn also become toxic at high concentration, which is why, cellular uptake of metals his a heavily regulated process (Nies 1999).

Local anthropogenic activities and riverine inputs are largely responsible for the entry of contaminants in coastal and estuarine waters (Eggleton and Thomas 2004; Roldán-Wong *et al.* 2018). Mishaps such as Bento Rodrigues Dam (Brazil) burst of 2015 can introduce high amounts of heavy metals, some even radioactive in a short span. Presence of such metals can lead to cytotoxicity and DNA damage in local flora (Segura *et al.* 2016). Metals like Lead can form aerosols and can get

transported far away from their sources (Horta-Puga *et al.* 2014). Upon their entry in the environment, various physicochemical parameters like salinity, pH and oxidation potential influence the sorption of metals which result in enhanced bioavailability due to increased solubility (EPA 2007). Organisms on metal exposure can exhibit varied response with different life stages in the same organism meaning that certain larval stages show higher susceptibility of metal induced damage over others (Liao *et al.* 2019). The bacterial response to metal exposure can be variable ranging from production of siderophores to uptake iron (Carvalho and Fernandes 2010, Granger and Price 1999) to expression of metallothioneins, a class of metal chelating proteins (Valls and De Lorenzo 2002) or single stranded DNA breaks (Mitra and Bernstein 1978). With increasing occurrences of fishes, crabs and molluscs being contaminated with heavy metals (Pempkowiak *et al.* 1999; Ahmad *et al.* 2010; Zhao *et al.* 2010; Maulvault *et al.* 2012; Naccari *et al.* 2015; Giripunjeet *et al.* 2016, Delgado-Alvarez *et al.* 2019), finding solutions to remove these metals from aquatic systems is essential. Several factors are responsible for metal sorption in water as given in figure 1. These factors need to be considered to determine the exact fate of metals in the environment which changes course of bioremediation strategies. Most metals in their native form and some metal compounds do not tend to solubilize easily. When their soluble forms are utilized for studies, there is a bias in estimating their bioavailability and toxicity which is a major concern in designing toxicological studies (EPA 2007).

The detoxification mechanism by different genus of bacteria against the same metal may not be the same. Hg has been observed to be removed by volatilization in *Bacillus cereus* (Dash *et al.* 2016) or by surface adsorption as shown by *Pseudomonas* spp. (Deng and Wang 2012). This means that bioremediation strategies should take into account the detoxification process in order to determine course of action. The current study illustrates role played by marine microbes and the different responses exhibited by them in presence of heavy metals. With growing interest in understanding use of biological systems like algae, bacteria and fungi for bioremediation (Giripunjeet *et al.* 2015; Ayangbenro and Babalola 2017; Rajendran *et al.* 2003), the response rendered by marine bacteria can be useful in dealing specifically with marine pollution, where terrestrial microbes cannot survive owing to hypersaline conditions.

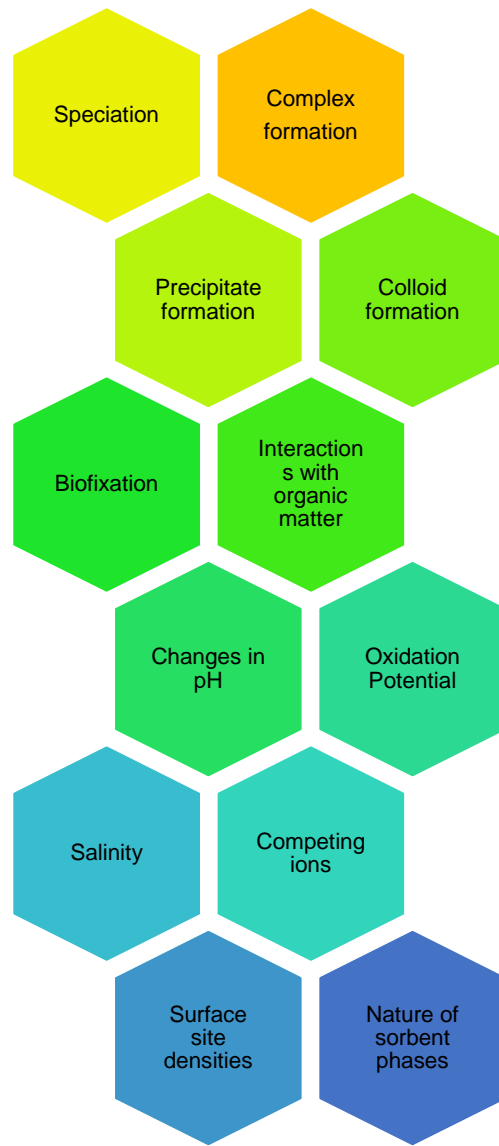

Fig. 1. Factors affecting sorption of metals (Based on EPA 2007)

2. Mechanisms:

Marine bacteria are known to be adaptive towards fluctuating biological, chemical and physical conditions which are evident from the biochemical pathways and physiological adaptations made by them (Carvalho and Fernandes 2010). Similarly, bacteria exposed to metals develop mechanisms to resist them (Bruins *et al.* 2000). Most of these mechanisms are either chromosomal, plasmid based or transposon based genes (Silver 1996; Rouchet *et al.* 1995; Osborn *et al.* 1995; Silver and Phung 1996). Often, plasmids carrying metal resistance genes show presence of antibiotic resistance genes too (Silver and Misra 1988) which has been attributed to the fact that presence of metals leads to selection of the said genes (Calomiris *et al.* 1984; Sabry *et al.* 1997). Vicente *et al.* (1990) isolated

strains *Pseudomonas aeruginosa* from sewage contaminated regions of coastal Spain which could resist simultaneous exposure of two antibiotics and a heavy metal with one isolate from highly polluted sea water being resistant to Hg, As and Cr. This could prove that multi-resistance for metals and antibiotics is possible in a single bacterium. Rouchet *al.* (1995) describe the mode for metal resistance where the choice of detoxification pathway depends upon presence of detoxification genes, site in the cell that requires protection and availability of nutrition. Metallothioneins (MT), known to exist in eukaryotes, act as metal sequestering proteins. The first report of prokaryotic MT was observed in marine cyanobacterium *Synechococcus* sp. It was seen that the MTs rendered tolerance to *Synechococcus* sp. against cadmium (Olafson *et al.* 1979).

Metals may also be cell bound or precipitated thereby reducing their toxic effects (Jayshankar *et al.* 2007). There can also be an active or passive uptake of metals, enabling metal bioaccumulation (Marques 2016). Certain bacteria possess specific operons targeting detoxification of metals. An extensively studied operon system targeting Mercury, *mer* operon, produces an NAD(P)H dependant protein, MerA, which is responsible for reducing toxic mercuric Hg(II) ion to a volatile form of elemental mercury Hg(0) which can vaporise out of the solution (Allen 2013). Here, changes in oxidation state has reduced the toxicity of metal. Using similar processes, bacteria detoxify toxic heavy metal ions to their less toxic oxidation states (Ayangbenro and Babalola 2017).

Number of factors are responsible for the choice of means of protection and the degree of protection offered by the system in question. That includes

1. The number and type of metal uptake system
2. The role played by the metal in normal metabolism
3. The availability of resistance genes for metals which could either be chromosomal, carried on plasmid or transposons (Rouchet *al.* 1995)

Cell membranes only allow diffusion of H₂O, CO₂, N₂, NH₃, O₂, B(OH)₃ and Si(OH)₃ and they require entrapping molecules to ensure loss due to them diffusing out of the cell (Williams 1981). Usually whenever uptake of metals is involved, a transporter protein is imperative owing to the fact that biological membranes are highly impermeable to hydrophilic ions like metal cations (Anderson 1978; Rouchet *al.* 1995). Figure 2 summarises some of the common responses rendered by microbes in presence of heavy metals.

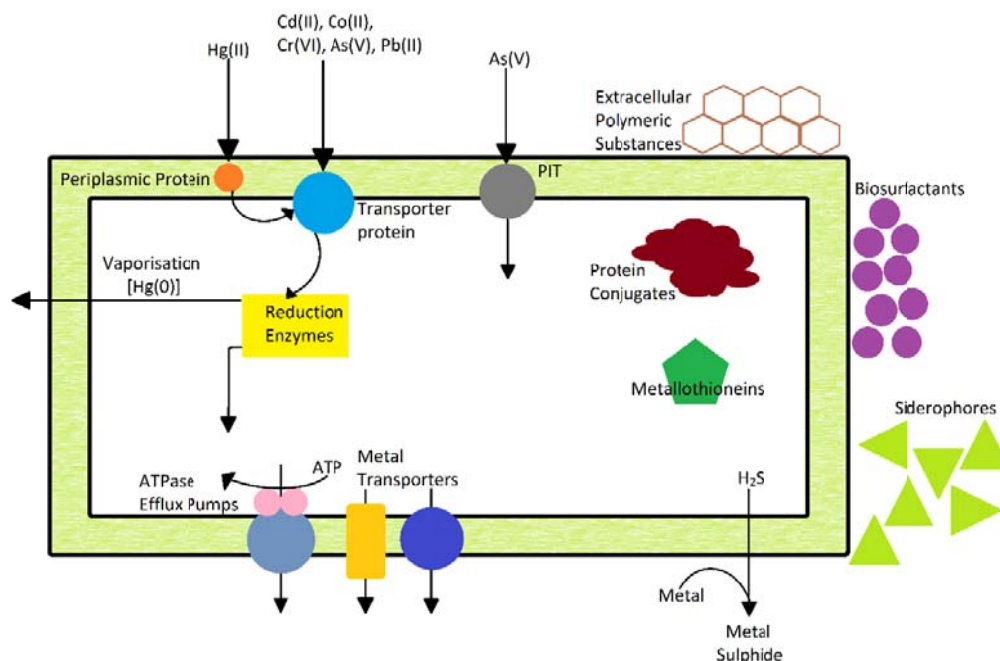

Fig. 2. Summarisation of pathways for metal removal / detoxification

Table 1 describes about studies done to determine median lethal dose(LD₅₀) value and Minimum Inhibition Concentration (MIC) used routinely in toxicology to determine potency of a toxin.

Table 1. LD₅₀ for mammals and MIC values of *Serratia* sp. WPR3 for common heavy metals

Metal	LD ₅₀ for mammals (Adapted from Bowen1979) in mg/kg BW(bodyweight)	MIC for <i>Serratia</i> sp. WPR3 (Adapted from Jafarzadeet al. 2012) in mg L ⁻¹
Cd	1.3	NG ^a [CdSO ₄]
Co	50	400-450 [CoSO ₄ ·7H ₂ O]
Cr	90	600 [Cr(NO ₂) ₃ ·9H ₂ O]
Cu	–	NG ^a [CuSO ₄]
Hg	1.5	NG ^a [HgCl ₂]
Mn	18	750-800 [MnSO ₄ ·H ₂ O]
Ni	110-220	450-500 [NiSO ₄]
Pb	70	750 [Pb(NO ₃) ₂]
Zn	–	700-750 [ZnSO ₄]

^a No growth was observed

Several studies have been conducted on microbes isolated from marine waters, sediments and deep-sea hydrothermal vents. Areas with reported heavy metal contamination due to anthropogenic activities were chosen for these studies. Hydrothermal vents show presence of heavy metals due to occurrence of volcanic activity under the seabed (Loaëcet al. 1997).

2.1 Non-Specific response against metals

2.1.1 Metabolism independent biosorption

Biosorption is an energy independent process involving ionic or physiochemical adsorption by dead or living cells. It is to be noted that metabolic pathways in living cells may influence biosorption (White *et al.* 1995; Hassan *et al.* 2010). Functional groups like carboxyl, amine, hydroxyl, phosphate and sulphhydryl are known to interact with metal ions in their vicinity (Hassan *et al.* 2010; Gadd 2009; Hoyle and Beveridge 1984). With bacterial cell wall being largely negatively charged, it may localize positively charged metal ions on the cell surface (Beveridge 1981; Hoyle and Beveridge 1984). This ultimately is instrumental in attracting metal ions in the vicinity of the bacterial cell to get attracted to this highly anionic surface and adsorb.

2.1.2 Extracellular Polymeric Substances

Extracellular Polymeric substances (EPS) also known as exopolysaccharides are diverse organic polymeric compounds with tremendous industrial applications, particularly in Biotechnology (Suresh Kumar *et al.* 2007; Freitaset *al.* 2011). They are composed of osidic monomers with organic or inorganic substituents like phosphate, sulphate, or lactate, succinate and pyruvate groups (Delbarre-Ladratet *al.* 2014). EPS possess high affinity to dissolved compounds in sea water which includes metals (Decho 1990; Bhaskar and Bhosle 2006). As a result, bacteria producing EPS are expected to trap metal ions on their cell surface. *Bacillus cereus* BW 201B (Dash *et al.* 2016), *Alteromonasmacleodiisubspfiensis* (Loaëcet *al.* 1997), *Enterobacter cloacae* (Iyeret *al.* 2004) isolated from diverse marine environments showed metal biosorption through EPS binding. As EPS has highest partition coefficient among known biosorbents, organisms capable of producing it have advantage of its greater binding ability to metals (Quigley *et al.* 2002; Bhaskar and Bhosle 2006). Thus EPS offer a permeability barrier against heavy metals through which entry of toxic metals is altogether avoided thus protecting sensitive cellular components (Bruins *et al.* 2000).

2.1.3 Biosurfactants

Microorganisms are capable of producing surface active substances also referred to as surfactants which help in either reducing surface tension or allow tight binding to surfaces (Ron and Rosenberg 2011). They are amphiteric, which means that they are composed of a hydrophilic end with moieties like an acid, peptide, cations or anions, or saccharide units and a hydrophobic end moiety like hydrocarbons or fatty acids. Low molecular weight compounds called biosurfactants are usually glycolipids or lipopeptides, whereas high-molecular-weight polymers called bioemulsans comprise of polysaccharides, lipopolysaccharide proteins or lipoproteins units (Banat *et al.* 2010).

Biosurfactants have application in bioremediation owing to their ability to form metal complexes. Metals tend to have a greater affinity for ionic surfactants over matrix, as a result, they form complexes and get desorbed from the matrix. Cationic biosurfactants can bind to metals via ion exchange or electrostatic interactions (Aşçı *et al.* 2008; Pacwa-Płociniczak *et al.* 2011). A biosurfactant producing *Bacillus* sp., MTCC 5514 isolate from marine sample from Tamil Nadu, India showed tolerance of 2000 mg L⁻¹ of Hexavalent Chromium, a known carcinogen (Gnanamaniet *et al.* 2010). Since these substances are produced outside the cell, biosurfactants have been produced using fermentation techniques which exhibit promising remediation activity (Juwarkaret *et al.* 2007; Gnanamaniet *et al.* 2010).

2.1.4 Sulphide based precipitation

Sulphate reducing bacteria (SRB) is a group of chemolithotropic bacteria which can utilise diverse group of compounds as electron donors and are able to integrate anaerobic electron transport with ATP synthesis. With about 200 species spread across 60 genera, SRB have displayed their significance in bioremediation due to their ability to metabolise hydrocarbons and detoxify ions like Cr(VI) and U(VI) (Barton and Fauque 2009).

They utilise sulphur instead of oxygen as the terminal electron acceptor using the following pathway described in Fu and Wang (2011)



Here, CH₃CH(OH)COOH stands for simple organic compounds. This generated hydrogen sulphide can react with aqueous metal ions, thereby forming their corresponding sulphides and precipitating them.

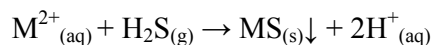

Metal sulphides have extremely low solubility (Bhattacharyya *et al.* 1979) and thus the precipitate remains stable which ensures that they become immobile and biologically unfavorable (Harithsa *et al.* 2002). Such a non-specific response is beneficial not just for the bacterium itself, but for other organisms in the vicinity as well.

2.1.5 Metal binding with proteins

Metals are known to bind to biomolecules such as chelators, glutathione derived peptides called phytochelatin and other metal binding peptides. Binding to such molecules facilitates absorption and transport of metal ions in bacterial cells. Heavy metals are also known to disrupt enzyme functions by binding to thiol (-SH) and other protein groups or by replacing co-factors which renders them

inactive (Ayangbenro and Babalola 2017). Metallothioneins (MTs) are a class of cysteine rich proteins capable of metal binding found across all domains of life. The abundance of Cys residues gives access to several metal binding thiol groups (Gutiérrez *et al.* 2019). MTs are capable of sequestering both essential as well as toxic transition metals by internally forming polynuclearmetalthiolate clusters (Calvo *et al.* 2017). MTs are ubiquitous, and thus are found across several taxonomic groups. However, research on prokaryotic MTs is largely limited (Gutiérrez *et al.* 2019). Presence of MTs has been reported in *Pseudomonas* and marine cyanobacterium *Synechococcus* (Olafson *et al.* 1979; Hingham *et al.* 1984). Both these isolates were found to be growing in presence of Cd^{2+} (Blindauer 2011). In eukaryotes, MTs are reported to be metallated sequentially and show presence of hemimetallated MTs (Krężel and Maret 2007) which indicates presence of more than one metal binding location. It has been seen that MTs are capable of binding to divalent cations of Zn^{2+} , Cd^{2+} , Cu^{2+} , and Hg^{2+} (Calvo *et al.* 2017; Gutiérrez *et al.* 2019).

2.2 Specific response against metals

2.2.1 Chromosomal and Plasmid based genes for transport / biotransformation / efflux

Intercellular compounds, metal-binding proteins, intracellular precipitation, methylation, and other mechanisms allow bacterial cells to imbibe metals and associate themselves with cellular components (Hassan *et al.* 2010). This can involve chromosomal genes responsible for transport of metals ions of Iron, Nickel, Manganese, Zinc and Cobalt (Silver and Walderhaug 1992) or plasmid encoded genes in case of metals like Arsenic, Copper, Mercury and Cadmium (Silver and Walderhaug 1992; Kaur and Rosen 1992; Nies 1999). Silver and Walderhaug (1992) observed a common trait in chromosomally mediated ion transport that were presence of multiple transport system for each ion; a constitutive expression of low affinity and high capacity transport system, another being a facultative expression of high affinity and low capacity transport system in response to nutrient deprivation. The genes expressed chromosomally are also involved in essential metal tolerance which tend to be more complex than plasmid based systems (Silver and Walderhaug 1992; Bruins *et al.* 2000). The plasmid encoded determinants allow for the bacterium to resist and efflux toxic ions (Bruins *et al.* 2000). Zolgharnein *et al.* (2007) observed that heavy metal resistant bacteria isolated from industrially contaminated sea water and sediments from Persian Gulf showed greater occurrence of plasmids than natural bacteria which suggests possibility of greater abundance of plasmid encoded tolerance genes over chromosome encoded tolerance genes for metals. Once the metal enters the cells it is lead to the subsequent biotransformation or efflux outside the cell.

a) Mercury

Mercury (Hg) has largely been recognized as being toxic in all of its chemical forms (Broussard *et al.* 2002). It enters aquatic ecosystem through both natural phenomena like degassing, volcanic eruptions, leaching of metal from ores like cinnabar and rocks (Clarkson 1997; De *et al.* 2003; Gworek *et al.* 2016) as well as anthropogenic reasons like industrial and municipal effluents, coal and metal mining and dentistry (Clarkson 1997; De *et al.* 2003; Dash 2014). With no apparent biological role (EPA 2007) and being non-biodegradable, its presence in the environment is of serious concern (De *et al.* 2008). The LD₅₀ value of Hg for mammals is 1 mg/kg BW which makes it toxic to life forms even at low concentrations (Bowen 1979). Hg behaves differently in its elemental form, as inorganic salts and as organometallic compounds with varying degree of toxicity (Langford and Ferner 1999). Bacteria acquire genes for resistance through plasmids and/or transposons (Silver and Walderhaug 1992; Osborn *et al.* 1995). The most common method of detoxification of Hg involves *mer* operon which transcribes for mercury reductase (MerA). This results in a NAD(P)H dependent reduction of Hg(II) to Hg(0), a relatively non-toxic form of Hg to bacteria, which volatilizes in the atmosphere (Dash and Das 2012). The *mer* operon operates at relatively low concentrations of mercury salts, thus implying role of Hg(II) as a sensor leading to the switching on of the operon (Misra 1992). When Hg(II) enters the cell envelope, it may be bound in the periplasmic space to a Hg(II) binding protein MerP which facilitates its entry inside the bacterial cell with the help of Hg transporter system. MerP is a periplasmic protein which has cysteine residues which have high specificity for Hg²⁺. Transmembrane protein MerT is responsible for transport of the Hg²⁺ ions to mercury reductase (MerA) (DeSilva *et al.* 2002; Zhang *et al.* 2020). Cytoplasmic MerA reduces Hg(II) to elemental mercury [Hg(0)] which can then be volatilized thus detoxifying the metal (Rouchet *et al.* 1995, Bruins *et al.* 2000). While most marine bacteria exhibit such MerA mediated removal, recent studies show that bacteria where MerA function is not strong as in the case of *Pseudomonas pseudoalcaligenes* S1 isolated from a mangrove bay in China, MerP and MerT end up accumulating Hg retaining it in the periplasm instead of transporting inside the cell. This could be an alternative strategy towards detoxification of Hg (Zhang *et al.* 2020). Hg is also methylated by marine microbes resulting in accumulation of methylmercury (Gionfriddo *et al.* 2016).

Studies have focused on understanding pathway through which Hg is tolerated or removed from the system. *Acinetobacter* and *Bacillus* spp. isolated from mangrove sediments along Qatari coast showed significant tolerance against Hg and was studied to remove mercury from powdered fluorescent lamps. It was observed that a *Bacillus marisflavi* isolate showed up to 96.7% removal efficiency of Hg (Abu-Dieyeh *et al.* 2019). Mercury tolerant *Pseudomonas*-10 isolate found as a part

of gut microbiota in *Daphnia* rendered tolerance against mercury by detoxifying Hg(II) to Hg(0) (Fong *et al.* 2019). Water and sediment isolates from Xixiang Estuary, Shenzhen Bay, China were studied for tolerance of Hg²⁺ along with other metals like Nickel, Cadmium and Chromium and discovered a *Pseudomonas* sp. which was able to tolerate a maximum of 120 mg L⁻¹ Hg²⁺ and was able to tolerate Hg through surface biosorption (Deng and Wang 2012). *Bacillus cereus* BW 201B isolated from water sample off coastal Odisha, India was able to tolerate 50 mg L⁻¹ of Hg as HgCl₂ and showed *mer*-operon based Hg volatilisation (Dash *et al.* 2017). Consortia isolated from Antarctic coast was seen to be producing methylmercury and volatilize Hg (Gionfriddo *et al.* 2016). *Pseudomonas aeruginosa* CH07 isolated from Chennai coast showed tolerance to 75 mg L⁻¹ of Hg as HgCl₂ through volatilization (Jayshankar *et al.* 2007). An isolate of *Enterobacter cloacae* studied by Iyer *et al.* (2005) showed EPS based biosorption for Cd, Cu and Co, however remarkably did not show any biosorption for Hg. Figure 2 shows detoxification of Hg(II) through *mer* operon.

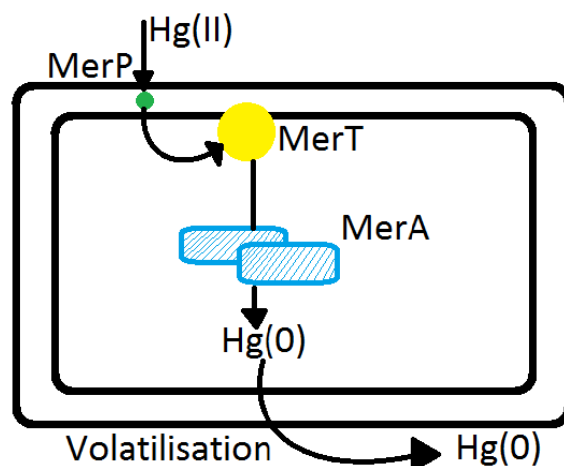

Fig 2. Detoxification mechanism of Hg(II) (Adapted from Nies 1999)

b) Arsenic

Arsenic (As) is a toxic metalloid, which has been historically known as a homicidal agent and is known to contaminate groundwater (Lee *et al.* 2005; Nagvenkar and Ramaiah 2009). Naturally, it is known to occur almost ubiquitously in all biotic and abiotic components (Mandal and Suzuki 2002). Natural weathering of rocks, volcanoes, riverine input along with industries, effluents and mining activities introduces As in the environment (Nagvenkar and Ramaiah 2009; Lee *et al.* 2005). Its acute effects include cancer of the bladder, skin and liver (Mandal and Suzuki 2002; Lee *et al.* 2005). Its LD₅₀ value for mammals is 5 mg/kg BW (Bowen 1979) which implies that relatively miniscule quantities of As are enough to produce its toxic effects. Chemically it is found as As(V) AsO₄³⁻ or As(III) AsO₂⁻ with As(V) resembling phosphate (PO₄³⁻) thus interfering with phosphate metabolism

(Nies 1999). Phosphate and arsenate enter the cell either through PIT (phosphate inorganic transport) protein or Pst system. It is this interference which makes removal of arsenate from the cell particularly difficult. This is overcome by utilizing ArsC to convert arsenate to arsenite which can be effluxed out in an energy dependent process (Willsky and Malamy 1980; Nies and Silver 1995; Nies 1999). Some bacteria show presence of ABC family of genes for arsenate uptake (Papadopoulou *et al.* 1994; Nies 1999). The efflux involves use of arsenate operon (*ars* operon) which codes for three to five genes namely *arsR*, *arsA*, *arsD*, *arsB*, *arsC* which code for an ATPase efflux pump system (Rouche *et al.* 1995; Bruins *et al.* 2000). As(V) is effluxed from the cell as trivalent arsenic by arsenite efflux permease *ArsB*. ATP driven *ArsA* helps by enhancing efflux mechanism. *ArsR* acts as a negative repressor of the operon and senses inorganic arsenic, thus repressing activity of the operon. Catalysis of transformation of As(V) to As(III) is carried out by *ArsC* which acts as an arsenate reductase (Wu and Rosen 1991; Ji and Silver 1992; Dey and Rosen 1995; Yan *et al.* 2018). *Marinomonas communis* IAM 12914 studied by Takeuchi *et al.* (2007) showed the bacterium to tolerate a maximum of 5 mg L⁻¹ As as Na₂HAsO₄·7H₂O. The isolate was seen to remove As and localize it on cell membrane via cell surface adsorption. Mercury resistant bacterium *Bacillus thuringiensis* PW-05 isolated from Odisha coast, India by Dash *et al.* (2014) was seen to be tolerant against As and could withstand 232.4 mg L⁻¹ As as Na₂HAsO₄. An Enterobacteriaceae member FW3 isolated from consortia from water and sediment samples in Mandovi estuary, Goa, India (Nagvenkar and Ramaiah 2009) was seen to uptake and biotransform As. Figure 3 shows detoxification of As(V).

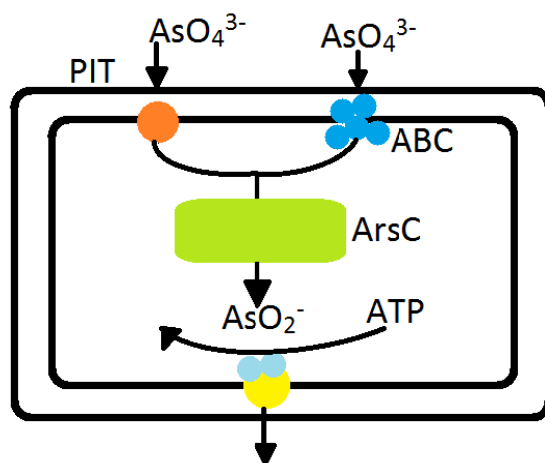

Fig 3. Detoxification mechanism of As(V) (Adapted from Nies 1999)

c) Cadmium:

Although being found in trace amounts on earth surface, Cadmium (Cd) is reported for being toxic even at low concentrations (Trevorset *al.* 1986; El-Helowet *al.* 2000). The LD₅₀ value of Cd for mammals is 1.3mg/kg BW(body weight)(Bowen 1979) thus confirming its toxic effects with exposure to miniscule quantities. It is known to induce DNA damage in *E. coli* (Mitra and Bernstein 1978) and has been used as an industrial bactericide (Babich and Stotzky 1978). Physiologically, Cadmium is known to be denaturing protein and binding with thiols. It interferes with calcium and zinc metabolism and results in membrane damage, loss of protective function ((Neis 1999). Cadmium enters cells through divalent ion transporters, which are usually responsible for transport of essential divalent ions. It is seen that Mn²⁺ transport systems are also responsible for Cd uptake (Laddaga and Silver 1985; Silver and Walderhaug 1992). The unique feature of Cd tolerance is that there is no enzymatic detoxification involved which is observed in Hg(II) or As(V) (Bruins *et al.* 2000). Efflux of Cd occurs through a set of genes belonging to *czc* and *cad* systems. The gene *czc* is also responsible for transport of zinc and cobalt. Protein *cadA*, coded by *cad* system is an ATPase homolog which helps in efflux of Cd²⁺. Thus, the metal is removed from the system without changes in oxidation states. *Alteromonasmacleodii* subsp. *fijiensis* isolated from hydrothermal vents off Fiji, Pacific Ocean was seen to resist 1000 mg L⁻¹ of Cd and produced EPS to resist entry of metal (Loaëcet *al.* 1997). *Vibrio harveyi* 5S-2 isolated from Alexandria harbor, Egypt was seen to bioaccumulate Cd (Abd-Elnabyet *al.* 2011). Fig. 4 shows detoxification of Cd.

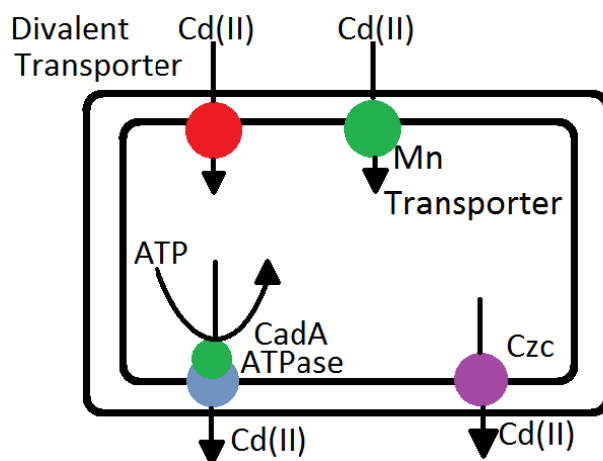

Fig. 4 Detoxification mechanism of Cd(II) (Adapted from Nies 1999)

d) Chromium

Chromium (Cr) is an industrially important metal. Its main industrial use is in the manufacturing stainless steel (Barnhart 1997). In India, it has been used in industrial cooling towers as a virtue of its

corrosion preventing action and biocidal properties (Bhide *et al.* 1996). Among its chemical species, Cr is most abundantly found as dichromate [Cr(III)] and chromate [Cr(VI)] (Pechova and Pavlata 2007). Cr(VI) is one of the most common constituent of tannery effluents (Srinath *et al.* 2002; Vijayraj *et al.* 2019). Hexavalent Cr is known to be a potent mutagen and carcinogen (Iyer *et al.* 2004; Ramírez-Díaz *et al.* 2007) and has no apparent biological significance for microorganisms (Nies 1999). Chromate ion (CrO_4^{2-}) is chemically anionic which is unlike other metals. This affects the cell response against the ion as it is not affected by anionic surface of the cell (Beveridge 1981; Cervantes *et al.* 2001). In bacterial cells the sulphate transport system has been identified to be responsible for uptake of Cr(VI) where it acts as a competitive inhibitor owing to chemical analogy with SO_4^{2-} (Cervantes and Campos-García 2007). On entering the cell, it causes oxidative stress and induces DNA damage (Bridgewater *et al.* 1994; Ackerley *et al.* 2006). Cr(VI) is also responsible for bringing down cellular levels of glutathione and other free thiols (Ackerley *et al.* 2006). Since DNA can directly get affected by oxidative stress induced by Cr, its detoxification is necessary. Chromosomal genes are responsible for the enzymatic detoxification of Cr, whereas, plasmid based genes are mainly involved in efflux of Cr ions (Cervantes and Campos-García 2007; Cervantes *et al.* 2001). Chromate reductase reduces highly toxic Cr(VI) to less toxic Cr(III). ChrR, a chromate reductase isolated from *Pseudomonas putida* (Park *et al.* 2000) is one of the well-studied chromate reductases. They have been described with NADH:flavin oxidoreductase activity as primary function which is also capable of reducing chromate as a secondary function and show NADH dependency for its activity (Cervantes and Campos-García 2007). The reduced Cr, now as Cr(III) gets effluxed out of the cell through chromosomally expressed transporter proteins (Ramírez-Díaz *et al.* 2007). Fig. 5 shows detoxification of Cr(VI).

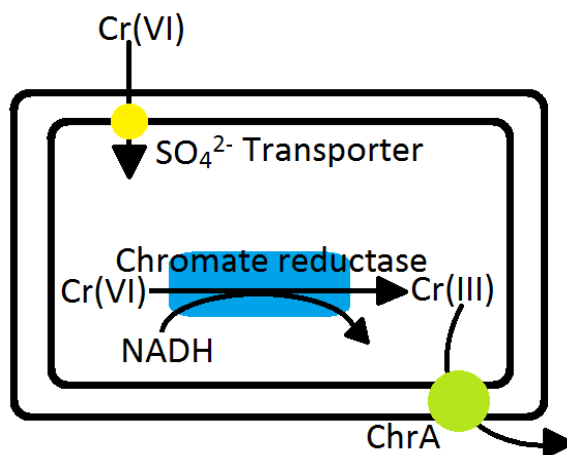

Fig. 5 Detoxification mechanism of Cr(VI) (Adapted from Ramírez-Díaz *et al.* 2007)

2.2.2 Siderophores

Iron (Fe) is an essential micronutrient for bacterial cells. In aerobic conditions Fe tends to form insoluble hydroxides and oxyhydroxides (Rajkumaret al. 2010). In order to sequester Fe(III) from their surroundings, bacteria are known to produce siderophores. Siderophores act as solubilizing agents which make Fe biologically available. On binding with siderophores, Fe³⁺ gets reduced to Fe²⁺ and utilized by the cell (Birch and Bachofen 1990; Rajkumaret al. 2010). There are three classes of siderophores viz. hydroxamates, catecholates, and carboxylates which are classified on the basis of ligand involved in metal chelation with Fe(III) (Sahaet al. 2015). Siderophores binding abilities are not just restricting to Fe, but they are also able to bind to non-essential metals like Ga(III), Cr(III), Al(III) and also essential metals like Mg, Mn, Ca (Birch and Bachofen 1990). This implies potential of siderophore producing microbes in bioremediation of heavy metals. Siderophore producing marine bacteria have been utilized for remedial of Cr contaminated tannery sewage (Vijayarajet al. 2019).

3. Implication of heavy metal pollution on marine biota

Rachel Carson in her 1962 book 'Silent Spring' raised concern about biomagnification and bioaccumulation. The book was instrumental in creating awareness about xenobiotics entering food chains through accumulation by plants and lower organisms. Marine environment exhibits similar pattern of biomagnification. A study on marine copepod *Acartiatonsa* by Lee and Fisher (2017) suggests that the organism is capable of accumulating Hg and methyl mercury. A model proposed by Schartupet al. (2017) showed uptake of methylmercury and trophic level transfer by plankton. Marine mussels *Mya arenaria* and *Astarte borealis* collected from Norwegian Sea and Baltic Sea showed accumulated levels of heavy metals (Pempkowiaket al. 1999). Edible crab *Cancer pagurus* caught from Scottish shore also showed presence of heavy metals in edible parts of the animal (Maulvaultet al. 2012). *Epinephelusareolatus*, *Lutjanusrusselli*, and *Sparussarba* from cultured pond sites in Hong Kong showed high levels of Zn, Pb and Cu (Wong et al. 2001). This illustrates that globally organisms across different trophic levels are accumulating heavy metals from their environment. Even controlled sites such as culture ponds are showing risk of contaminated water and bioaccumulation of metals in fishes (Wong et al. 2001). This poses a serious health risk to humans as most of the organisms mentioned above are routinely consumed by humans and thus become prone to effects of bioaccumulation and biomagnification of heavy metals.

4. Conclusion and future prospect

Marine environment is under a constant threat to exposure of pollutants which is an impending risk to all kinds of biota. Presence of metals which can alter or interfere homeostasis and metabolism can be extremely detrimental for the survival of all life forms. By understanding role played by marine organisms in metal detoxification, better strategies for wastewater treatment can be developed and in-situ infrastructure for 'ocean clean-up' can be planned. Due to very limited studies on marine microbes for their bioremediation potential, there is room for research in understanding specific physiology played by them which is not exhibited by terrestrial microbes. Future prospects of indigenous microbes showing high levels of metal tolerance are

Designing remediation technology

Developing strategies for metal recovery, especially for precious metals

Possible usage in ecological disasters for environmental management

Scaling up technologies for upgrading existing waste treatment facilities

Designing such remediation technology will be most promising considering increasing pollution of heavy metals in estuarine and coastal environment. Thus, bioremediation technology using such microbes against heavy metal contaminated wastes will be helpful in build a sustainable and eco-friendly marine ecosystem.

Acknowledgements

Authors are grateful to Director, CSIR-National Institute of Oceanography (CSIR-NIO), Goa, India and Scientist-in-Charge, CSIR-NIO, Regional Centre, Mumbai for their encouragement and support. This is the CSIR-NIO contribution number_____

References

1. Abd-Elnaby, H., Abou-Elela, G. M., and El-Sersy, N. A. (2011). Cadmium resisting bacteria in Alexandria Eastern Harbor (Egypt) and optimization of cadmium bioaccumulation by *Vibrio harveyi*. *African Journal of biotechnology*, *10*(17), 3412-3423.
2. Abu-Dieyeh, M. H., Alduroobi, H. M., & Al-Ghouti, M. A. (2019). Potential of mercury-tolerant bacteria for bio-uptake of mercury leached from discarded fluorescent lamps. *Journal of environmental management*, *237*, 217-227.
3. Ackerley, D. F., Barak, Y., Lynch, S. V., Curtin, J., and Matin, A. (2006). Effect of chromate stress on *Escherichia coli* K-12. *Journal of Bacteriology*, *188*(9), 3371-3381.
4. Ahmad, M. K., Islam, S., Rahman, M. S., Haque, M. R., and Islam, M. M. (2010). Heavy metals in water, sediment and some fishes of Buriganga River, Bangladesh. *International Journal of Environmental Research*, *4*(2), 321-332.
5. Aislabie, J., and Loutit, M. W. (1984). The effect of effluent high in chromium on marine sediment aerobic heterotrophic bacteria. *Marine environmental research*, *13*(1), 69-79.
6. Allen, R. C., Tu, Y. K., Nevarez, M. J., Bobbs, A. S., Friesen, J. W., Lorsch, J. R., ... and Hamlett, N. V. (2013). The mercury resistance (*mer*) operon in a marine gliding flavobacterium, *Tenacibaculum discolor* 9A5. *FEMS microbiology ecology*, *83*(1), 135-148.
7. Altenburger, R. (2010). 1: Understanding Combined Effects for Metal Co-Exposure in Ecotoxicology. In *Metal Ions in Toxicology: Effects, Interactions, Interdependencies* (pp. 1-26). Royal Society of Chemistry Great Britain.
8. Andersen, O. S. (1978). Permeability properties of unmodified lipid bilayer membranes. In *Concepts and Models* (pp. 369-446). Springer, Berlin, Heidelberg.
9. Aşçı, Y., Nurbaş, M., and Açıkel, Y. S. (2008). A comparative study for the sorption of Cd (II) by soils with different clay contents and mineralogy and the recovery of Cd (II) using rhamnolipid biosurfactant. *Journal of Hazardous Materials*, *154*(1-3), 663-673.
10. Ayangbenro, A., and Babalola, O. (2017). A new strategy for heavy metal polluted environments: a review of microbial biosorbents. *International journal of environmental research and public health*, *14*(1), 94.
11. Babich, H., and Stotzky, G. (1978). Effects of cadmium on the biota: influence of environmental factors. In *Advances in applied microbiology* (Vol. 23, pp. 55-117). Academic Press.
12. Banat, I. M., Franzetti, A., Gandolfi, I., Bestetti, G., Martinotti, M. G., Fracchia, L., Smyth T.J. and Marchant, R. (2010). Microbial biosurfactants production, applications and future potential. *Applied microbiology and biotechnology*, *87*(2), 427-444.
13. Barnhart, J. (1997). Occurrences, uses, and properties of chromium. *Regulatory toxicology and pharmacology*, *26*(1), S3-S7.

14. Barton, L. L., and Fauque, G. D. (2009). Biochemistry, physiology and biotechnology of sulfate-reducing bacteria. *Advances in applied microbiology*, 68, 41-98.
15. Beveridge, T. J. (1981). Ultrastructure, chemistry, and function of the bacterial wall. In *International review of cytology* (Vol. 72, pp. 229-317). Academic Press.
16. Bhaskar, P. V., and Bhosle, N. B. (2006). Bacterial extracellular polymeric substance (EPS): a carrier of heavy metals in the marine food-chain. *Environment International*, 32(2), 191-198.
17. Bhattacharyya, D., Jumawan Jr, A. B., and Grieves, R. B. (1979). Separation of toxic heavy metals by sulfide precipitation. *Separation Science and Technology*, 14(5), 441-452.
18. Bhide, J. V., Dhakephalkar, P. K., and Paknikar, K. M. (1996). Microbiological process for the removal of Cr (VI) from chromate-bearing cooling tower effluent. *Biotechnology Letters*, 18(6), 667-672.
19. Birch, L., and Bachofen, R. (1990). Complexing agents from microorganisms. *Experientia*, 46(8), 827-834.
20. Bowen, H. J. M. (1979). *Environmental chemistry of the elements*. Academic Press.
21. Bridgewater, L. C., Manning, F. C., Woo, E. S., and Patierno, S. R. (1994). DNA polymerase arrest by adducted trivalent chromium. *Molecular carcinogenesis*, 9(3), 122-133.
22. Broussard, L. A., Hammett-Stabler, C. A., Winecker, R. E., and Roper-Miller, J. D. (2002). The toxicology of mercury. *Laboratory medicine*, 33(8), 614-625.
23. Bruins, M. R., Kapil, S., and Oehme, F. W. (2000). Microbial resistance to metals in the environment. *Ecotoxicology and environmental safety*, 45(3), 198-207.
24. Buccolieri, A., Buccolieri, G., Cardellicchio, N., Dell'Atti, A., Di Leo, A., and Maci, A. (2006). Heavy metals in marine sediments of Taranto Gulf (Ionian Sea, southern Italy). *Marine chemistry*, 99(1-4), 227-235.
25. Calomiris, J. J., Armstrong, J. L., and Seidler, R. J. (1984). Association of metal tolerance with multiple antibiotic resistance of bacteria isolated from drinking water. *Appl. Environ. Microbiol.*, 47(6), 1238-1242.
26. Calvo, J., Jung, H., and Meloni, G. (2017). Copper metallothioneins. *IUBMB life*, 69(4), 236-245.
27. Carson, R. (1962). *Silent Spring*. Boston: Houghton Mifflin Company
28. Cervantes, C., and Campos-García, J. (2007). Reduction and efflux of chromate by bacteria. In *Molecular microbiology of heavy metals* (pp. 407-419). Springer, Berlin, Heidelberg.
29. Cervantes, C., Campos-García, J., Devars, S., Gutiérrez-Corona, F., Loza-Tavera, H., Torres-Guzmán, J. C., and Moreno-Sánchez, R. (2001). Interactions of chromium with microorganisms and plants. *FEMS microbiology reviews*, 25(3), 335-347.
30. Clarkson, T. W. (1997). The toxicology of mercury. *Critical reviews in clinical laboratory sciences*, 34(4), 369-403.

31. Dash, H. R., and Das, S. (2012). Bioremediation of mercury and the importance of bacterial mer genes. *International biodeterioration and biodegradation*, 75, 207-213.
32. Dash, H. R., Basu, S., and Das, S. (2017). Evidence of mercury trapping in biofilm-EPS and mer operon-based volatilization of inorganic mercury in a marine bacterium *Bacillus cereus* BW-201B. *Archives of microbiology*, 199(3), 445-455.
33. Dash, H. R., Mangwani, N., and Das, S. (2014). Characterization and potential application in mercury bioremediation of highly mercury-resistant marine bacterium *Bacillus thuringiensis* PW-05. *Environmental Science and Pollution Research*, 21(4), 2642-2653.
34. De Carvalho, C. C., and Fernandes, P. (2010). Production of metabolites as bacterial responses to the marine environment. *Marine drugs*, 8(3), 705-727.
35. De, J., Ramaiah, N., and Vardanyan, L. (2008). Detoxification of toxic heavy metals by marine bacteria highly resistant to mercury. *Marine Biotechnology*, 10(4), 471-477.
36. De, J., Ramaiah, N., Mesquita, A., and Verlekar, X. N. (2003). Tolerance to various toxicants by marine bacteria highly resistant to mercury. *Marine Biotechnology*, 5(2), 185-193.
37. Decho, A. W. (1990). Microbial exopolymer secretions in ocean environments: their role (s) in food webs and marine processes. *Oceanogr Mar Biol*, 28(737153), 9-16.
38. Delbarre-Ladrat, C., Siquin, C., Lebellenger, L., Zykwincka, A., and Colliec-Jouault, S. (2014). Exopolysaccharides produced by marine bacteria and their applications as glycosaminoglycan-like molecules. *Frontiers in chemistry*, 2, 85.
39. Delgado-Alvarez, C., Ruelas-Inzunza, J., Escobar-Sánchez, O., Covantes-Rosales, R., Pineda-Pérez, I. B., Osuna-Martínez, C. C., Aguilar-Juárez, M., Osuna-López, J., Voltolina, D., and Frías-Espéricueta, M. G. (2019). Metal Concentrations in Age-Groups of the Clam, *Megapitaria squalida*, from a Coastal Lagoon in Mexico: A Human Health Risk Assessment. *Bulletin of environmental contamination and toxicology*, 1-6.
40. Deng, X., and Wang, P. (2012). Isolation of marine bacteria highly resistant to mercury and their bioaccumulation process. *Bioresource technology*, 121, 342-347.
41. Eggleton, J., and Thomas, K. V. (2004). A review of factors affecting the release and bioavailability of contaminants during sediment disturbance events. *Environment international*, 30(7), 973-980.
42. El-Helow, E. R., Sabry, S. A., and Amer, R. M. (2000). Cadmium biosorption by a cadmium resistant strain of *Bacillus thuringiensis*: regulation and optimization of cell surface affinity for metal cations. *Biometals*, 13(4), 273-280.
43. Fong, J. C., De Guzman, B. E., Lamborg, C. H., & Sison-Mangus, M. P. (2019). The mercury-tolerant microbiota of the zooplankton *Daphnia* aids in host survival and maintains fecundity under mercury stress. *Environmental science & technology*.
44. Freitas, F., Alves, V. D., and Reis, M. A. (2011). Advances in bacterial exopolysaccharides: from production to biotechnological applications. *Trends in biotechnology*, 29(8), 388-398.

45. Fu, F., and Wang, Q. (2011). Removal of heavy metal ions from wastewaters: a review. *Journal of environmental management*, 92(3), 407-418.
46. Gadd, G. M. (2009). Biosorption: critical review of scientific rationale, environmental importance and significance for pollution treatment. *Journal of Chemical Technology and Biotechnology: International Research in Process, Environmental and Clean Technology*, 84(1), 13-28.
47. Gionfriddo, C. M., Tate, M. T., Wick, R. R., Schultz, M. B., Zemla, A., Thelen, M. P., ...and Moreau, J. W. (2016). Microbial mercury methylation in Antarctic sea ice. *Nature microbiology*, 1(10), 16127.
48. Giripunje, M. D., Fulke, A. B., and Meshram, P. U. (2015). Remediation techniques for heavy-metals contamination in lakes: A mini-review. *CLEAN–Soil, Air, Water*, 43(9), 1350-1354.
49. Giripunje, M. D., Fulke, A. B., and Meshram, P. U. (2016). Assessment of heavy metals and estimation of human health risk in Tilapia fish from Naik Lake of Nagpur, India.
50. Gnanamani, A., Kavitha, V., Radhakrishnan, N., Rajakumar, G. S., Sekaran, G., and Mandal, A. B. (2010). Microbial products (biosurfactant and extracellular chromate reductase) of marine microorganism are the potential agents reduce the oxidative stress induced by toxic heavy metals. *Colloids and Surfaces B: Biointerfaces*, 79(2), 334-339.
51. Granger, J., and Price, N. M. (1999). The importance of siderophores in iron nutrition of heterotrophic marine bacteria. *Limnology and Oceanography*, 44(3), 541-555.
52. Gutiérrez, J. C., de Francisco, P., Amaro, F., Díaz, S., and Martín-González, A. (2019). Structural and Functional Diversity of Microbial Metallothionein Genes. In *Microbial Diversity in the Genomic Era* (pp. 387-407). Academic Press.
53. Gworek, B., Bemowska-Kalabun, O., Kijeńska, M., and Wrzosek-Jakubowska, J. (2016). Mercury in marine and oceanic waters—a review. *Water, Air, and Soil Pollution*, 227(10), 371.
54. Harithsa, S., Kerkar, S., and Bharathi, P. L. (2002). Mercury and lead tolerance in hypersaline sulfate-reducing bacteria. *Marine pollution bulletin*, 44(8), 726-732.
55. Hassan, S. H., Awad, Y. M., Kabir, M. H., Oh, S. E., and Joo, J. H. (2010). Bacterial biosorption of heavy metals. *Biotechnology: cracking new pastures*, 79-110.
56. Hawkes, S. J. (1997). What is a "heavy metal"? *Journal of Chemical Education*, 74(11), 1374.
57. Higham, D. P., Sadler, P. J., and Scawen, M. D. (1984). Cadmium-resistant *Pseudomonas putida* synthesizes novel cadmium proteins. *Science*, 225(4666), 1043-1046.
58. Horta-Puga, G., and Carriquiry, J. D. (2014). The last two centuries of lead pollution in the southern Gulf of Mexico recorded in the annual bands of the scleractinian coral *Orbicella faveolata*. *Bulletin of environmental contamination and toxicology*, 92(5), 567-573.

59. Hoyle, B. D., and Beveridge, T. J. (1984). Metal binding by the peptidoglycan sacculus of *Escherichia coli* K-12. *Canadian journal of microbiology*, 30(2), 204-211.
60. Iyer, A., Mody, K., and Jha, B. (2004). Accumulation of hexavalent chromium by an exopolysaccharide producing marine Enterobacteriaceae. *Marine pollution bulletin*, 49(11-12), 974-977.
61. Iyer, A., Mody, K., and Jha, B. (2005). Biosorption of heavy metals by a marine bacterium. *Marine Pollution Bulletin*, 50(3), 340-343.
62. Jafarzade, M., Mohamad, S., Usup, G., and Ahmad, A. (2012). Heavy-metal tolerance and antibiotic susceptibility of red pigmented bacteria isolated from marine environment. *Natural Resources*, 3(04), 171.
63. Jaishankar, M., Tseten, T., Anbalagan, N., Mathew, B. B., and Beeregowda, K. N. (2014). Toxicity, mechanism and health effects of some heavy metals. *Interdisciplinary toxicology*, 7(2), 60-72.
64. Jaysankar, D., Ramaiah, N., Bhosle, N. B., Garg, A., Vardanyan, L., Nagle, V. L., and Fukami, K. (2007). Potential of mercury-resistant marine bacteria for detoxification of chemicals of environmental concern. *Microbes and Environments*, 22(4), 336-345.
65. Ji, G., and Silver, S. (1992). Reduction of arsenate to arsenite by the ArsC protein of the arsenic resistance operon of *Staphylococcus aureus* plasmid pI258. *Proceedings of the National Academy of Sciences*, 89(20), 9474-9478.
66. Juwarkar, A. A., Nair, A., Dubey, K. V., Singh, S. K., and Devotta, S. (2007). Biosurfactant technology for remediation of cadmium and lead contaminated soils. *Chemosphere*, 68(10), 1996-2002.
67. Kaur, P., and Rosen, B. P. (1992). Plasmid-encoded resistance to arsenic and antimony. *Plasmid*, 27(1), 29-40.
68. Keil, D. E., Berger-Ritchie, J., and McMillin, G. A. (2011). Testing for toxic elements: a focus on arsenic, cadmium, lead, and mercury. *Laboratory Medicine*, 42(12), 735-742.
69. Khambhaty, Y., Mody, K., Basha, S., and Jha, B. (2009). Biosorption of Cr (VI) onto marine *Aspergillus niger*: experimental studies and pseudo-second order kinetics. *World Journal of Microbiology and Biotechnology*, 25(8), 1413.
70. Krężel, A., and Maret, W. (2007). Different redox states of metallothionein/thionein in biological tissue. *Biochemical Journal*, 402(3), 551-558.
71. Laddaga, R. A., and Silver, S. (1985). Cadmium uptake in *Escherichia coli* K-12. *Journal of Bacteriology*, 162(3), 1100-1105.
72. Langford, N. J., and Ferner, R. E. (1999). Toxicity of mercury. *Journal of human hypertension*, 13(10), 651.
73. Lee, C. S., and Fisher, N. S. (2017). Bioaccumulation of methylmercury in a marine copepod. *Environmental toxicology and chemistry*, 36(5), 1287-1293.

74. Lee, J. U., Lee, S. W., Kim, K. W., and Yoon, C. H. (2005). The effects of different carbon sources on microbial mediation of arsenic in arsenic-contaminated sediment. *Environmental geochemistry and health*, 27(2), 159-168.
75. Liao, W., Feng, C., Liu, N., Liu, D., Yan, Z., Bai, Y., Xie, H., Shi, H. and Wu, D. (2019). Influence of Hardness and Dissolved Organic Carbon on the Acute Toxicity of Copper to Zebrafish (*Danio rerio*) at Different Life Stages. *Bulletin of Environmental Contamination and Toxicology*, 1-7.
76. Lippert, K., and Galinski, E. A. (1992). Enzyme stabilization by ectoine-type compatible solutes: protection against heating, freezing and drying. *Applied microbiology and biotechnology*, 37(1), 61-65.
77. Loaić, M., Olier, R., and Guezennec, J. (1997). Uptake of lead, cadmium and zinc by a novel bacterial exopolysaccharide. *Water Research*, 31(5), 1171-1179.
78. Mandal, B. K., and Suzuki, K. T. (2002). Arsenic round the world: a review. *Talanta*, 58(1), 201-235.
79. Marques, C. R. (2016). Bio-rescue of marine environments: On the track of microbially-based metal/metalloid remediation. *Science of The Total Environment*, 565, 165-180.
80. Maulvault, A. L., Anacleto, P., Lourenço, H. M., Carvalho, M. L., Nunes, M. L., and Marques, A. (2012). Nutritional quality and safety of cooked edible crab (*Cancer pagurus*). *Food chemistry*, 133(2), 277-283.
81. Misra, T. K. (1992). Bacterial resistances to inorganic mercury salts and organomercurials. *Plasmid*, 27(1), 4-16.
82. Mitra, R. S., and Bernstein, I. A. (1978). Single-strand breakage in DNA of *Escherichia coli* exposed to Cd²⁺. *Journal of bacteriology*, 133(1), 75-80.
83. Mohapatra, R. K., Parhi, P. K., Pandey, S., Bindhani, B. K., Thatoi, H., and Panda, C. R. (2019). Active and passive biosorption of Pb (II) using live and dead biomass of marine bacterium *Bacillus xiamenensis* PbRPSD202: Kinetics and isotherm studies. *Journal of environmental management*, 247, 121-134.
84. Mohseni, M., Abbaszadeh, J., Maghool, S. S., and Chaichi, M. J. (2018). Heavy metals detection using biosensor cells of a novel marine luminescent bacterium *Vibrio* sp. MM1 isolated from the Caspian Sea. *Ecotoxicology and environmental safety*, 148, 555-560.
85. Mukkata, K., Kantachote, D., Wittayaweerarak, B., Techkarnjanaruk, S., Mallavarapu, M., and Naidu, R. (2015). Distribution of mercury in shrimp ponds and volatilization of Hg by isolated resistant purple nonsulfur bacteria. *Water, Air, and Soil Pollution*, 226(5), 148.
86. Naccari, C., Cicero, N., Ferrantelli, V., Giangrosso, G., Vella, A., Macaluso, A., Naccari, F., and Dugo, G. (2015). Toxic metals in pelagic, benthic and demersal fish species from Mediterranean FAO zone 37. *Bulletin of environmental contamination and toxicology*, 95(5), 567-573.
87. Nagvenkar, G. S., and Ramaiah, N. (2010). Arsenite tolerance and biotransformation potential in estuarine bacteria. *Ecotoxicology*, 19(4), 604-613.

88. Nies, D. H. (1999). Microbial heavy-metal resistance. *Applied microbiology and biotechnology*, 51(6), 730-750.
89. Nies, D. H., and Silver, S. (1995). Ion efflux systems involved in bacterial metal resistances. *Journal of industrial microbiology*, 14(2), 186-199.
90. Olafson, R. W., Abel, K., and Sim, R. G. (1979). Prokaryotic metallothionein: preliminary characterization of a blue-green alga heavy metal-binding protein. *Biochemical and biophysical research communications*, 89(1), 36-43.
91. Osborn, A. M., Bruce, K. D., Strike, P., and Ritchie, D. A. (1995). Sequence conservation between regulatory mercury resistance genes in bacteria from mercury polluted and pristine environments. *Systematic and applied microbiology*, 18(1), 1-6.
92. Pacwa-Płociniczak, M., Płaza, G. A., Piotrowska-Seget, Z., and Cameotra, S. S. (2011). Environmental applications of biosurfactants: recent advances. *International journal of molecular sciences*, 12(1), 633-654.
93. Papadopoulou, B., Roy, G., Dey, S., Rosen, B. P., and Ouellette, M. (1994). Contribution of the Leishmania P-glycoprotein-related gene *ltgpgA* to oxyanion resistance. *Journal of Biological Chemistry*, 269(16), 11980-11986.
94. Park, J. D., and Zheng, W. (2012). Human exposure and health effects of inorganic and elemental mercury. *Journal of preventive medicine and public health*, 45(6), 344.
95. Pechova, A., and Pavlata, L. (2007). Chromium as an essential nutrient: a review. *VETERINARNI MEDICINA-PRAHA*, 52(1), 1.
96. Pempkowiak, J., Sikora, A., and Biernacka, E. (1999). Speciation of heavy metals in marine sediments vs their bioaccumulation by mussels. *Chemosphere*, 39(2), 313-321.
97. Petukh, M., and Alexov, E. (2014). Ion binding to biological macromolecules. *Asian journal of physics: an international quarterly research journal*, 23(5), 735.
98. Quigley, M. S., Santschi, P. H., Hung, C. C., Guo, L., and Honeyman, B. D. (2002). Importance of acid polysaccharides for ²³⁴Th complexation to marine organic matter. *Limnology and Oceanography*, 47(2), 367-377.
99. Rainbow, P. S., and Furness, R. W. (1990). Heavy metals in the marine environment. *CRC PRESS, BOCA RATON, FL(USA)*, 1-3.
100. Rajendran, P., Muthukrishnan, J., and Gunasekaran, P. (2003). Microbes in heavy metal remediation. *Indian Journal of Experimental Biology*, 41, 935-944.
101. Rajkumar, M., Ae, N., Prasad, M. N. V., and Freitas, H. (2010). Potential of siderophore-producing bacteria for improving heavy metal phytoextraction. *Trends in biotechnology*, 28(3), 142-149.
102. Ramírez-Díaz, M. I., Díaz-Pérez, C., Vargas, E., Riveros-Rosas, H., Campos-García, J., and Cervantes, C. (2008). Mechanisms of bacterial resistance to chromium compounds. *Biometals*, 21(3), 321-332.

103. Roldán-Wong, N. T., Kidd, K. A., Ceballos-Vázquez, B. P., and Arellano-Martínez, M. (2018). Is There a Risk to Humans from Consuming Octopus Species from Sites with High Environmental Levels of Metals?. *Bulletin of environmental contamination and toxicology*, 101(6), 796-802.
104. Ron, E. Z., and Rosenberg, E. (2001). Natural roles of biosurfactants: Minireview. *Environmental microbiology*, 3(4), 229-236.
105. Rouch, D. A., Lee, B. T., and Morby, A. P. (1995). Understanding cellular responses to toxic agents: a model for mechanism-choice in bacterial metal resistance. *Journal of industrial microbiology*, 14(2), 132-141.
106. Rousk, J., and Rousk, K. (2018). Responses of microbial tolerance to heavy metals along a century-old metal ore pollution gradient in a subarctic birch forest. *Environmental pollution*, 240, 297-305.
107. Sabry, S. A., Ghazlan, H. A., and Abou-Zeid, D. M. (1997). Metal tolerance and antibiotic resistance patterns of a bacterial population isolated from sea water. *Journal of applied microbiology*, 82(2), 245-252.
108. Saha, M., Sarkar, S., Sarkar, B., Sharma, B. K., Bhattacharjee, S., and Tribedi, P. (2016). Microbial siderophores and their potential applications: a review. *Environmental Science and Pollution Research*, 23(5), 3984-3999.
109. Saito, M. A., Moffett, J. W., Chisholm, S. W., and Waterbury, J. B. (2002). Cobalt limitation and uptake in *Prochlorococcus*. *Limnology and Oceanography*, 47(6), 1629-1636.
110. Sakpirom, J., Kantachote, D., Siripattanakul-Ratpukdi, S., McEvoy, J., and Khan, E. (2019). Simultaneous bioprecipitation of cadmium to cadmium sulfide nanoparticles and nitrogen fixation by *Rhodospseudomonas palustris* TN110. *Chemosphere*, 223, 455-464.
111. Saranya, K., Sundaramanickam, A., Shekhar, S., and Swaminathan, S. (2019). Biosorption of mercury by *Bacillus thuringiensis* (CASKS3) isolated from mangrove sediments of southeast coast India.
112. Schartup, A. T., Qureshi, A., Dassuncao, C., Thackray, C. P., Harding, G., and Sunderland, E. M. (2017). A model for methylmercury uptake and trophic transfer by marine plankton. *Environmental science and technology*, 52(2), 654-662.
113. Segura, F. R., Nunes, E. A., Paniz, F. P., Paulelli, A. C. C., Rodrigues, G. B., Braga, G. Ú. L., ... and Batista, B. L. (2016). Potential risks of the residue from Samarco's mine dam burst (Bento Rodrigues, Brazil). *Environmental Pollution*, 218, 813-825.
114. Shah, S., and Damare, S. R. (2018). Differential protein expression in a marine-derived *Staphylococcus* sp. NIOSBK35 in response to arsenic (III). *3 Biotech*, 8(6), 287.
115. Silver, S. (1992). Plasmid-determined metal resistance mechanisms: range and overview. *Plasmid*, 27(1), 1-3.
116. Silver, S. (1996). Bacterial resistances to toxic metal ions-a review. *Gene*, 179(1), 9-19.

117. Silver, S., and Misra, T. K. (1988). Plasmid-mediated heavy metal resistances. *Annual Reviews in Microbiology*, 42(1), 717-743.
118. Silver, S., and Phung, L. T. (1996). Bacterial heavy metal resistance: new surprises. *Annual review of microbiology*, 50(1), 753-789.
119. Silver, S., and Walderhaug, M. (1992). Gene regulation of plasmid- and chromosome-determined inorganic ion transport in bacteria. *Microbiology and Molecular Biology Reviews*, 56(1), 195-228.
120. Suresh Kumar, A., Mody, K., and Jha, B. (2007). Bacterial exopolysaccharides—a perception. *Journal of basic microbiology*, 47(2), 103-117.
121. Takeuchi, M., Kawahata, H., Gupta, L. P., Kita, N., Morishita, Y., Ono, Y., and Komai, T. (2007). Arsenic resistance and removal by marine and non-marine bacteria. *Journal of biotechnology*, 127(3), 434-442.
122. Trevors, J. T., Stratton, G. W., and Gadd, G. M. (1986). Cadmium transport, resistance, and toxicity in bacteria, algae, and fungi. *Canadian Journal of Microbiology*, 32(6), 447-464.
123. US Environmental Protection Agency. (2007). Framework for metals risk assessment. *US Environmental Protection Agency, Office of the Science Advisor: Washington, DC. EPA 120/R-07/001*.
124. Valls, M., and De Lorenzo, V. (2002). Exploiting the genetic and biochemical capacities of bacteria for the remediation of heavy metal pollution. *FEMS microbiology Reviews*, 26(4), 327-338.
125. Vicente, A. D., Aviles, M., Codina, J. C., Borrego, J. J., and Romero, P. (1990). Resistance to antibiotics and heavy metals of *Pseudomonas aeruginosa* isolated from natural waters. *Journal of Applied Bacteriology*, 68(6), 625-632.
126. Vijayaraj, A. S., Mohandass, C., and Joshi, D. (2019). Microremediation of tannery wastewater by siderophore producing marine bacteria. *Environmental technology*, 1-14.
127. Wang, C. L., Michels, P. C., Dawson, S. C., Kitisakkul, S., Baross, J. A., Keasling, J. D., and Clark, D. S. (1997). Cadmium removal by a new strain of *Pseudomonas aeruginosa* in aerobic culture. *Appl. Environ. Microbiol.*, 63(10), 4075-4078.
128. White, C., Wilkinson, S. C., and Gadd, G. M. (1995). The role of microorganisms in biosorption of toxic metals and radionuclides. *International Biodeterioration and Biodegradation*, 35(1-3), 17-40.
129. Williams, R. J. P. (1981). Physico-chemical aspects of inorganic element transfer through membranes. *Philosophical Transactions of the Royal Society of London. B, Biological Sciences*, 294(1071), 57-74.
130. Willsky, G. R., and Malamy, M. H. (1980). Effect of arsenate on inorganic phosphate transport in *Escherichia coli*. *Journal of bacteriology*, 144(1), 366-374.

131. Wong, C. K., Wong, P. P. K., and Chu, L. M. (2001). Heavy metal concentrations in marine fishes collected from fish culture sites in Hong Kong. *Archives of Environmental Contamination and Toxicology*, 40(1), 60-69.
132. Zhao, S., Feng, C., Quan, W., Chen, X., Niu, J., and Shen, Z. (2012). Role of living environments in the accumulation characteristics of heavy metals in fishes and crabs in the Yangtze River Estuary, China. *Marine pollution bulletin*, 64(6), 1163-1171.
133. Zolgharnein, H., Azmi, M., Lila, M., ZamriSaad, M., Rahim Mutalib, A., Mohamed, R., and Abd, C. (2007). Detection of plasmids in heavy metal resistance bacteria isolated from the Persian Gulf and enclosed industrial areas. *Iranian Journal of Biotechnology*, 5(4), 232-239.
134. Zwolak, I. (2015). Increased cytotoxicity of vanadium to CHO-K1 cells in the presence of inorganic selenium. *Bulletin of environmental contamination and toxicology*, 95(5), 593-598.